

QUASAR
H O L L A N D



Julia Wall lamp

NL Installatie handleiding

DE Installationsanleitung

EN Installation manual

1 NL Informatie / DE Information/ EN Information



Veiligheidsinformatie

- Onderbreek altijd de stroomtoevoer door verwijderen van de toestelzijdige stop bij de montage, onderhoudswerk en het verwisselen van de gloeilampen.
- Een brandende lamp is heet. Let op brandgevaar.

Sicherheitshinweise

- Bei Montage, Wartungsarbeiten und Leuchtmittelwechsel immer Stromzufuhr durch Entfernen der bauseitigen Sicherung unterbrechen.

Wenn die Leuchte in Betrieb ist, besteht beim Glühmittel Verbrennungsgefahr!

Safety information

- During installation, maintenance work and change of illuminants always interrupt the power supply by removing the respective circuit breaker.

• When switched on, the lamp may cause burns when touched.

Technische informatie



IP20



- Ingangsspanning 120 of 240V
- Beschermingsklasse I
- Beschermingsgraad IP20
- De lamp mag niet in openlucht gebruikt worden
- LED: max 5W
- Technische gelijkvormigheid volgens EN-Richtlijnen

Technische Hinweise

- Eingangsspannung 120 oder 240V
- Schutzklasse I
- Schutzart IP20
- Leuchte darf nicht im Freien verwendet werden.
- LED: max 5W
- Technische Konformität gemäss EU-Richtlinien

Technical data

- Input voltage 120 or 240V
- Safety class I
- Degree of protection IP20
- Lamp must not be used in the open.
- LED: max 5W
- Technical conformity according to European EN-Regulations

Onderhoudsinformatie



- De lampen reinigen met in de handel verkrijgbare, niet-agressieve en niet-schurende reinigingsmiddelen
- Gebruik een plumeau

Pflegehinweise

- Leuchten nur mit handelsüblichen, nicht aggressiven und scheuernden Reinigungsmitteln reinigen.
- Gebrauch eine Federbesen

Maintenance information

- Lights should only be cleaned using commercially available, non-aggressive, non-scouring cleaning agents.
- Use a feather duster

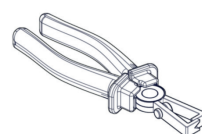
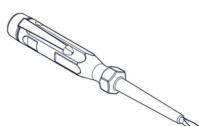
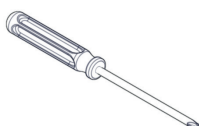
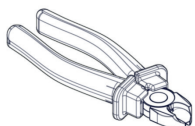
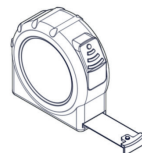
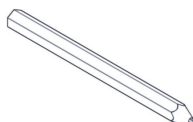
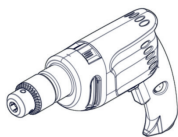
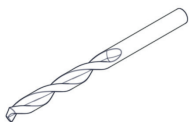

2.1 NL Installatie / EN Installation / DE Installation

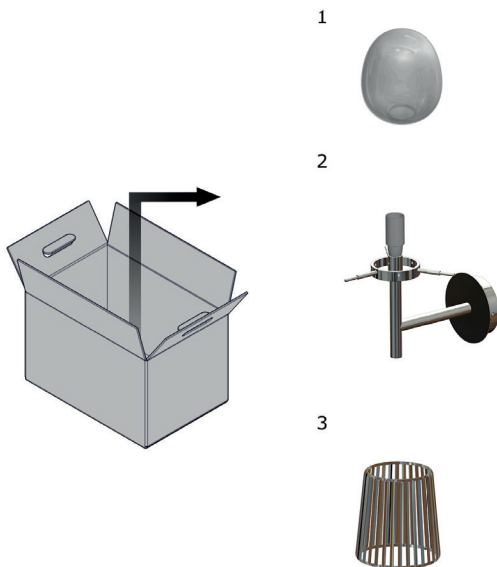

2.2

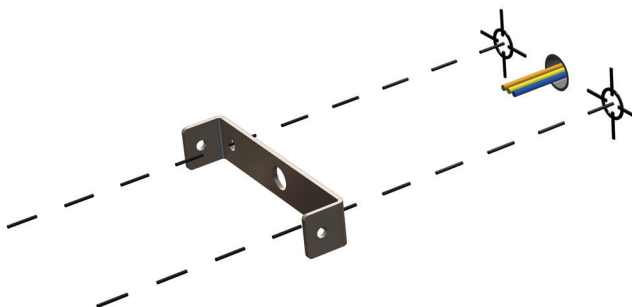
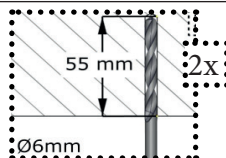
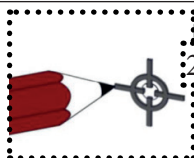
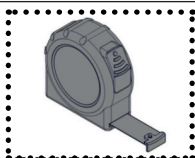
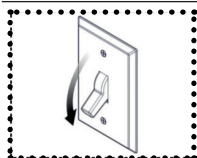

3.1 NL Installatie / EN Installation / DE Installation

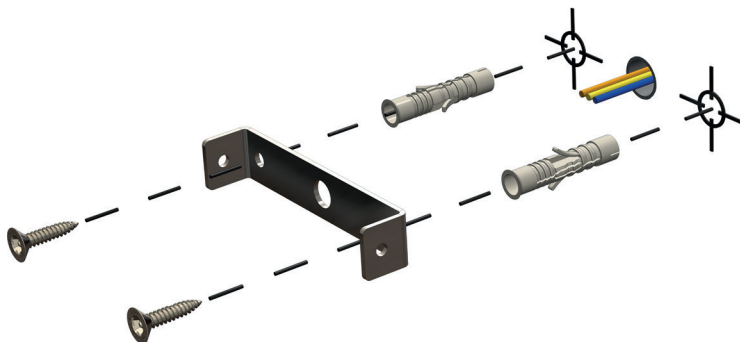
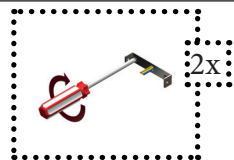

3.2

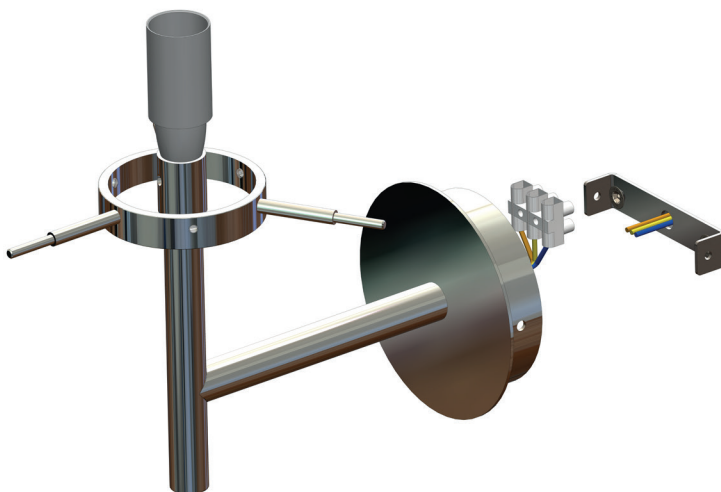

3.1 NL Installatie / EN Installation / DE Installation

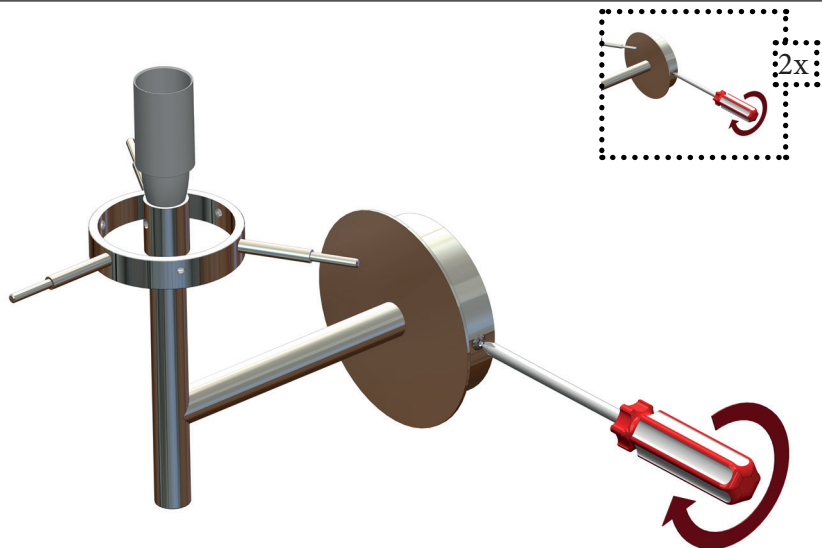

3.2

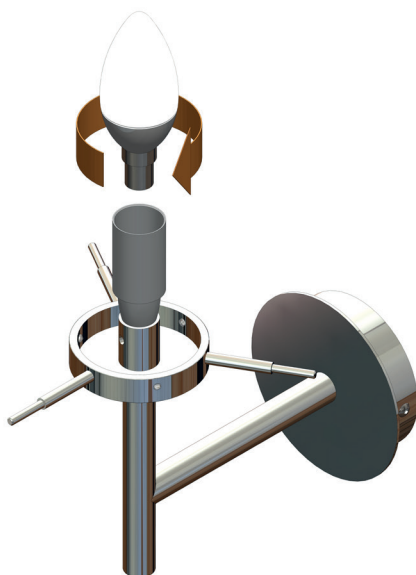

3.1 NL Installatie / EN Installation / DE Installation

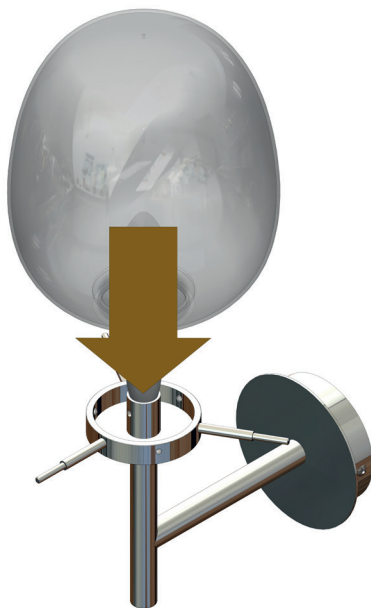

3.2

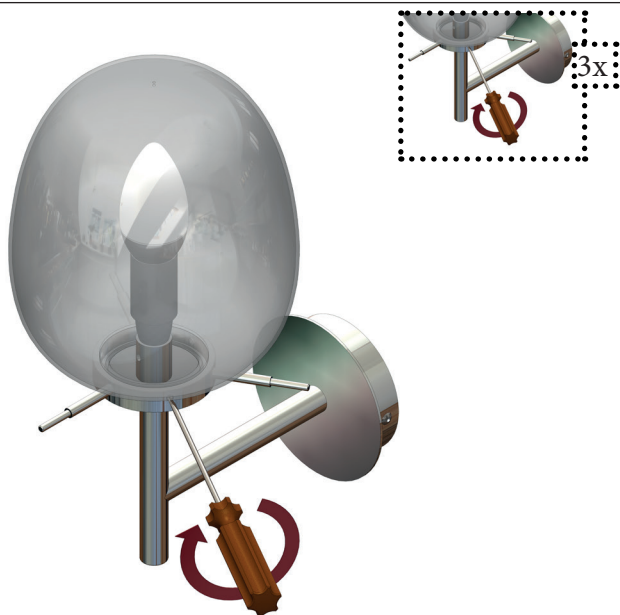

3.1 NL Installatie / EN Installation / DE Installation



3.2

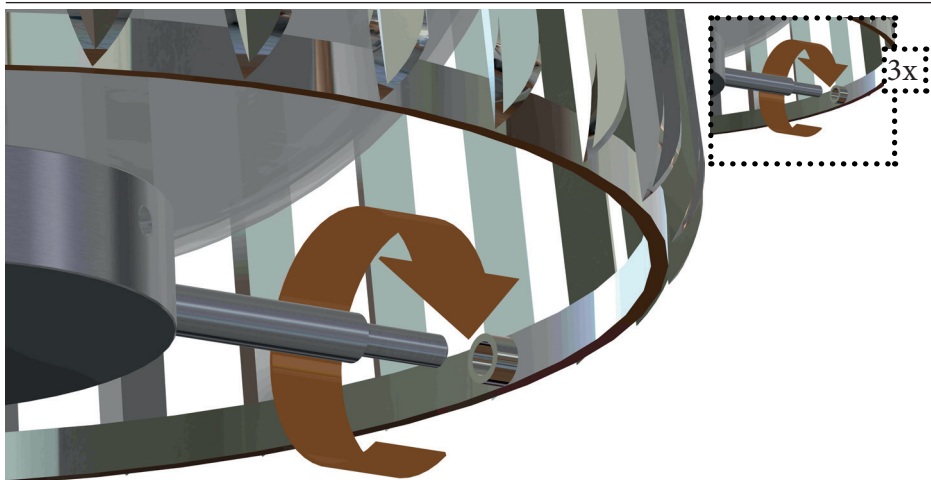

3.1 NL Installatie / EN Installation / DE Installation



Blank lined writing area consisting of 24 horizontal lines.



Quasar Holland B.V.
Burgstraat 2
4283 GG GIESSEN
THE NETHERLANDS

T. 31-183-447887
E. info@quasar.nl
I. www.quasar.nl

Date: 20-06-2018
Version: 1